

APPLICATION:

Sight glass flanges with weld-on sockets are suitable for welding into pipelines, boilers, tanks, vacuum applications and equipment of all kinds. Possible applications are wherever visual inspections of filling or flow are required. Equally suitable for liquids and gases, they are particularly recommended for special constructions in various fields of application.

INSTALLATION NOTE:

After welding the base flange onto/into the pressure vessel, the sealing surface must be checked for deformations! Reworking may be required! Observe the listed torque values for remounting the cover flange! The pressure rating does not consider the base flange. This will have to be audited together with the pressure vessel according to AD 2000 instructions B9 or equivalent standard!

With welding socket according to DIN 1091-1 ($\Delta P \leq -1^1$ bis 16 bar)

Operating conditions:

Temperature: (depending on glass and gasket)	220 °C	
Pressure:	$\leq -1^1$ bis 16	Bar
Higher temperatures on request		

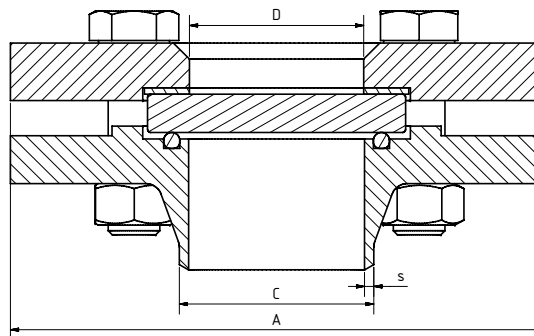

Materials:

Flange:	1.4571; 1.4404; 1.4539; 1.4462; 1.4435; 1.4541; 1.4306; C-Stahl
Glass:	Borosilicate glass DIN 7080 Soda lime glass DIN 8902
Gasket:	PTFE; FKM; NBR; Silicone; EPDM
Screws:	A4-70
Special materials on request	

DN	25	40	50	65	80	100	125	150
A	115	150	165	185	200	220	250	285
C	33,7	48,3	60,3	76,1	88,9	114,3	139,7	168,3
s	2,6	2,6	2,9	2,9	3,2	3,6	4	4,5
D	24	24	24	24	24	24	24	24
kg	28,5	43,1	55	70,1	82,5	107	131,7	160
Nm	35 ²	35 ²	35 ²	35 ²	35 ²	35 ²	35 ²	35 ²

¹ Depending on environmental variables ² graphite gasket (dimensions for PN16, further pressure ratings on request)



Round sight glass fitting PN 16 - vacuum

Welding socket acc. to DIN 1092-1 Type 11

Type 390V

PRODUCTCODE:

Group	TYPE	DN	PN	Base flange*	Glass	Gasket	Variant
11	390V	25	1: 16 2: Special	1: C-Steel	1: Borosilicate glass (Boro) DIN 7080 2: Soda lime glass (SLG) DIN 8902 5: Quartz glass 6: Boro DIN 7080 with PTFE wiper 7: Boro DIN 7080 with silicone wiper 8: SLG DIN 8902 with PTFE wiper 9: SLG DIN 8902 with silicone wiper 10: Sapphire glass	1: PTFE 2: FKM 3: NBR 5: Silicone 6: EPDM 8: Special	Assigned by ACI if required
		40		2: 1.4571			
		50		3: 1.4404			
		65		4: 1.4306			
		80		5: 1.4539			
		100		6: 1.4462			
		125		7: 1.4435			
		150		8: 1.4541			
				9: Special			

INFO: Unless otherwise stated, the factory standard highlighted is supplied.

*Cover flange according to quotation / order confirmation.

SPECIAL DESIGNS/OPTIONS:

- a) Wiper SWI PTFE or silicone Wiper blade (max. 6 bar)
- b) LED or halogen lights, ATEX-certified, EX
- c) FEP protective screen
- d) Other options on request



EXAMPLE:

11-390V-100-1-2-1-1-0 equals the product code:

ACI Type 390V
DN100
PN16
Base flange 1.4571
borosilicate glass
gasket PTFE
standard version

ATTENTION!

The pressure-temperature limits according to DIN EN 1092-1 apply!

Our tool of the same name is available on our website for this purpose.

(www.ACI24.com, in the category Service, Tools)



RECOMMENDATION:

For aggressive media or steam, mica discs should be used to protect the glass.

Kontakt w Niemczech
ACI Industriearmaturen GmbH
Tel. +49 (0) 2403 748 850
info@aci24.com • www.aci24.com

Kontakt w Polsce:
Continental Trade Sp. z o.o.
tel. +48 22 670 11 81
office@continentaltrade.com.pl
<http://continentaltrade.com.pl>

20200210

Technical changes and errors reserved!