

APPLICATION:

For observation of filling and flow in pipelines. This sight glass allows reliable monitoring of the function and performance of individual equipment as well as entire installations.

Type 575 Angle flow sight glasses are suitable for mounting on flanges according to DIN EN 1092-1. The sight glasses are supplied pre-assembled and ready for installation.

INSTALLATION NOTE:

Gaskets suitable for the sealing surfaces should be used. The screw material should be equivalent to or higher than those of the sight glass body. Always use screws that match the hole pattern. If possible, the screw thread and the screw head should be lubricated.

Angle form with flange connections for DIN 1092-1 ($\Delta P \leq 400$ bar)

Operating conditions:

Temperature: (depending on glass and gasket)	150°C 280 °C	
Pressure:	≤ 400	Bar
¹ up to 1000 bar on request		

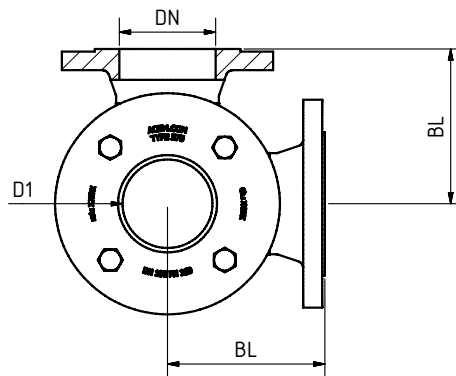

Materials:

Body:	1.4571; 1.4539; 1.4404
Glass:	Borosilicate glass DIN 7080 quartz glass mica META® glass sapphire glass
Gasket:	Graphite
Screws:	A4-70
Special materials on request	

DN	15	20	25	40	50	65	80	100	125	150	200
overall length (BL) ²	DIN EN 558-1 CTF 8 (DIN 3202 F32)										
flange dimensions	DIN EN 1092-1										
vista (D1)	on request or special dimensions										
² if possible											
Special dimensions and other standards on request											



High pressure sight glass PN 40 to PN 400

Sight glass in angle form with flange connections

Type 575

PRODUCTCODE:

Group	TYPE	DN	PN	Body*	Glass	Gasket	Variant
11	575	1: 15 2: 20 3: 25 4: 40 5: 50 6: 65 7: 80 8: 100 9: 125 10: 150 11: 200 12: Special	1: 40 2: 63 3: 100 4: 160 5: 250 6: 320 7: 400 8: Special	1: 1.4571 2: 1.4541 3: 1.4404 4: 1.4539 8: Special	1: Borosilicate glass (Boro) DIN 7080 2: Soda-Lime-Glass 3: Quartz glass 4: Boro + Mica 5: META®-Glass 8: Sapphire glass	7: Graphite 8: Special	Assigned by ACI if required

INFO: Unless otherwise stated, the factory standard highlighted is supplied.

* Cover flanges made of body material or according to quotation / order confirmation

SPECIAL DESIGNS/OPTIONS:

- a) double glazing
- b) Light version PN 10 to 40 (Type 570)
- b) Mica protection
- c) FEP protective screen
- d) LED or halogen lights, ATEX-certified, EX
- e) Additional options on request

EXAMPLE:

11-575-10-4-1-1-7-00 equals the product code
ACI Type 575
DN150
PN160
body 1.4571
borosilicate glass
gasket graphite
standard version

ATTENTION!

The pressure-temperature limits according to DIN EN 1092-1 apply!

Our tool of the same name is available on our website for this purpose.
(www.ACI24.com, in the category Service, Tools)



RECOMMENDATION:

For aggressive media or steam, mica discs should be used to protect the glass.

Kontakt w Niemczech
ACI Industriearmaturen GmbH
Tel. +49 (0) 2403 748 850
info@aci24.com • www.aci24.com

Kontakt w Polsce:
Continental Trade Sp. z o.o.
tel. +48 22 670 11 81
office@continentaltrade.com.pl
<http://continentaltrade.com.pl>

20191108

Technical changes and errors reserved!